

型號	MODEL	BA-65	BA-65L
棒材長度	BAR LENGTH	1.2M	1.5M
機械總重	MACHINE WEIGHT	320 KGS	360 KGS
棒材直徑	BAR DIAMETER	5-65mm	
棒材容量	BAR CAPACITY	65mm/10pcs	
空壓供應	AIR PRESSURE	6 kgf / cm ² 70psi	
電源供應	POWER SUPPLY	220V	
消耗功率	POWER CONSUMPTION	200W	

若需要其他資料請上網查詢 Check our website for more details at www.barload.com.tw
 本公司保留設計變更的權利 Modifications are subject to change without prior notice.

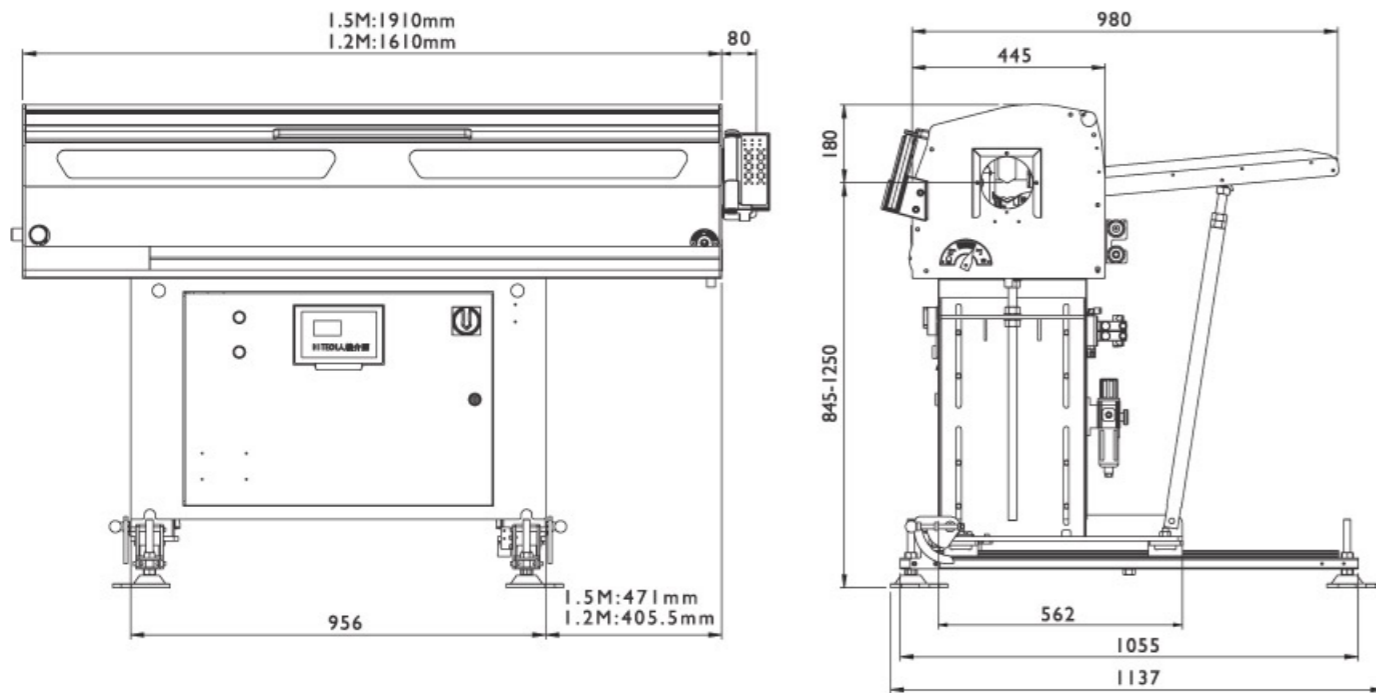

富豪機電股份有限公司
BARLOAD MACHINE CO., LTD.

No. 138, Wei-Hsin Road, Shi-Pai Li, Chang-Hua City, Taiwan 50080
 50080彰化市石牌里維新路138號
 TEL: +886-4-7384895 FAX: +886-4-7320282
 E-mail: info@barload.com.tw

www.barload.com.tw

經銷商 Agent



Jan Doustraat 37
 1689 XK Zwaag (NH)
 The Netherlands

Tel. +31(0)85 0022937
info@tholitec.nl
www.tholitec.nl

本公司保留設計變更的權利 All Rights Reserved.

1493210000213CE-1



www.barload.com.tw



創新研發 · 台灣領航
 品質追求 · 世界第一

Quality Innovation
 Reliability Experience

BA 65
 系列 Series
 5 - 65 mm

SHORT BAR FEEDER

短棒材送料機



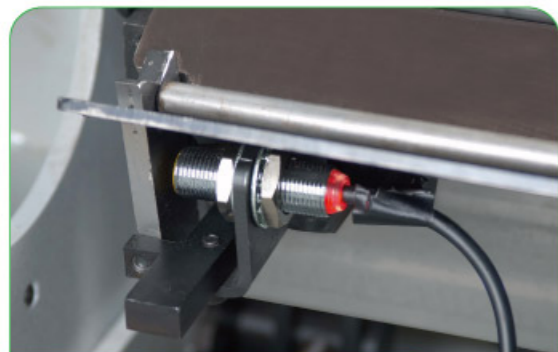

切端結構
Top-cut Configuration

- » 切端機構穩定，小棒材亦可精密偵測。
- » A top-cut device senses bar sizes accurately.

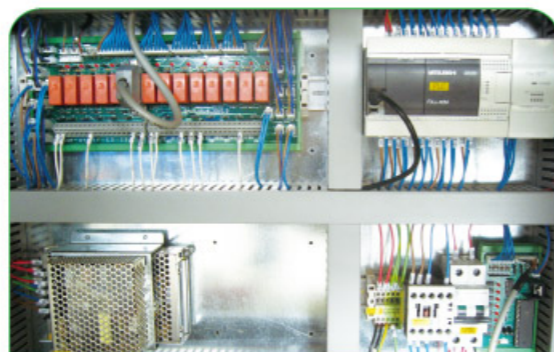

電控系統
Electrical System

- » 內部PLC控制，易與任何CNC車床搭配。
- » A PLC controller smartly interfaces with various fixed-type lathe source.

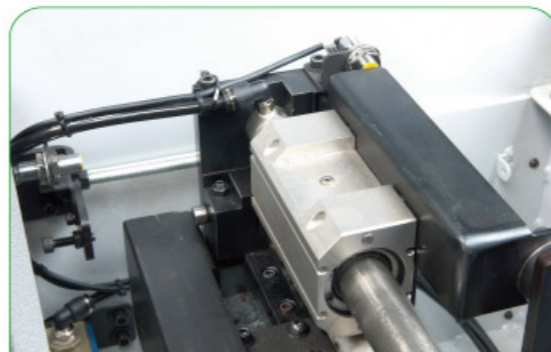

平移定位
Parallel Positioning

- » 定位機構，精準順暢。
- » A prompt shaft feeding.



送料—線性滑軌
Feeding-Linear-guide-way Device

- » 氣壓無桿缸與線性滑軌結合，動力輕盈順暢，不易脫磁。
- » A rodless-cylinder-and-linear-guide system functions efficiently.



中心調整
Adjustable Loading Center

- » 材料尺寸機構易於調整，簡單快速。
- » A quick changeover runs smoothly for bar sizes in diameters.



手控器
Movable Remote Controller

- » 手控盒，易於操作，符合人體工學。
- » A remote controller is as friendly-user.



移動式腳架
Retraction Device (Movable Rall)

- » 移動式腳盤，方便主軸維修，更換皮帶，主軸襯套。
(選購 X 向 及 Z 向 兩種規格)
- » Optional X or Z-axis device allows an easy change of lathe spindle liners.

- 可提昇CNC車床加工中，工件速度與精密度，無震動問題。
- 黑皮材料，可適用。
- BA-65送料機佔地空間小。
- 人機界面控制，操作與設定異常故障排除容易。
- 移動式手控盒，方便操作，符合人體工學。

- 線性滑軌推料，車床夾頭開時，使材料送達構料塊時，輕而順暢。
- 下料、調整機構，簡易方便。
- 移動式腳盤，方便主軸維修、更換皮帶、主軸襯套。(選購)
- 外部LED顯示位置棒材長度及異常訊息明顯易見。
- 新下料方式，減少噪音，調整方便。

- Increases productivity and cuts making cost hugely.
- Suits bar materials such as shapes & profiles.
- Requires no roomy space to accommodate it with.
- Friendly user with a human-machine-interface application.
- Feed materials accurately with a linear-guide system.
- An easy changeover with a V-channel-loading system.
- An external LED-stripe display features bar position & length while fed.
- Offers a free vibration condition with unlimited RPM.

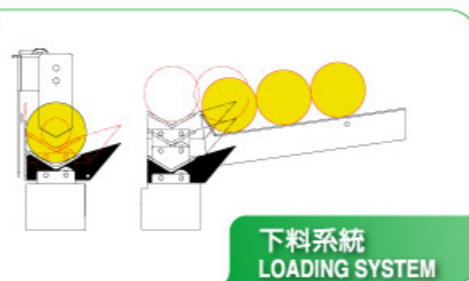

下料系統
LOADING SYSTEM

BA 65
系列 Series

SHORT BAR FEEDER

短棒材送料機